

NAME \_\_\_\_\_

## EET 150 Lab 4 Series-Parallel Circuits

### OBJECTIVES:

- Measure resistance, currents, and voltages in series-parallel circuits, and verify that the measured values agree with theoretical predictions.
- Verify that Kirchhoff's laws, the voltage-divider rule, and the current-divider rule apply to series-parallel circuits.

### PROCEDURE:

1. Select the resistors shown in Table A. Measure and record their actual resistances.  
**Throughout this lab, round all predicted values, measured values, and percentage errors to three significant digits.**

TABLE A: Resistor Values

Resistor I.D.	Nominal Value	Actual Value
R <sub>1</sub>	4.7 kΩ	
R <sub>2</sub>	1.5 kΩ	
R <sub>3</sub>	2.2 kΩ	
R <sub>4</sub>	5.6 kΩ	
R <sub>5</sub>	10 kΩ	
R <sub>6</sub>	1 kΩ	

2. The following pages contain diagrams of three series-parallel circuits. Use your knowledge of series-parallel circuits to predict the quantities listed in the table below each circuit diagram. Then build each circuit and measure the quantities. Record your measured values, along with percentage errors.
3. After completing all measurements, answer the questions listed below.

### QUESTIONS: (Type your answers on another sheet.)

1. Based on your data for Circuit 3, is the **voltage-divider rule** satisfied in this circuit? Explain, giving **one specific example** of how this rule either is or is not satisfied in that circuit, using actual *measured* values, not predicted values. As part of your answer, show your calculation, and discuss the percentage error between your calculated and measured values.
2. Repeat Question 1 for the **current-divider rule**.
3. Repeat Question 1 for **Kirchhoff's Voltage Law**.
4. Repeat Question 1 for **Kirchhoff's Current Law**.

**TECHNICAL CONCLUSION:** Re-read the objectives at the beginning of this lab. For each objective, briefly state what you've learned from the lab. Include some discussion of how far off (percentage errors) your measured values were from your predicted values.

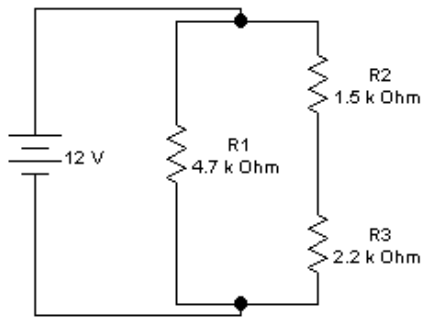

Circuit 1

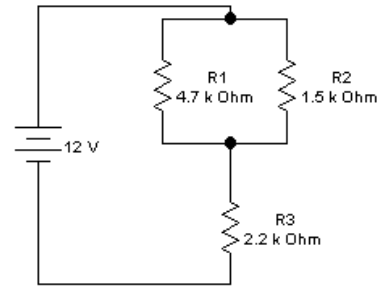

Circuit 2

**TABLE B: Currents and Voltages in Circuit 1**

Quantity	Predicted Value	Measured Value	DMM Range Used	% Error
$R_T$				
$I_T$				
$I_1$				
$I_2$				
$I_3$				
$V_1$				
$V_2$				
$V_3$				

**TABLE C: Currents and Voltages in Circuit 2**

Quantity	Predicted Value	Measured Value	DMM Range Used	% Error
$R_T$				
$I_T$				
$I_1$				
$I_2$				
$I_3$				
$V_1$				
$V_2$				
$V_3$				

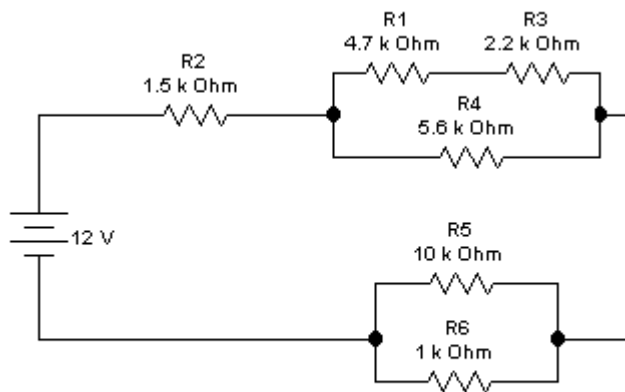

Circuit 3

**TABLE D: Currents and Voltages in Circuit 3**

Quantity	Predicted Value	Measured Value	DMM Range Used	% Error
$R_T$				
$I_T$				
$I_1$				
$I_2$				
$I_3$				
$I_4$				
$I_5$				
$I_6$				
$V_1$				
$V_2$				
$V_3$				
$V_4$				
$V_5$				
$V_6$				

**\*\*Don't forget to answer the questions listed on the first page of this lab. \*\***